

PROJECT:

FOR APPROVAL

CERTIFIED

MODEL PL25p PORTABLE VACUUM SYSTEM

STANDARD FEATURES:

1. 600 ICFM @ 14" Hg. CONTINUOUS
2. SUTORBILT 5L VACUUM PRODUCER
3. 25 HP LEESON MOTOR
4. FOUR (4) CARTRIDGES WITH TOTAL 244 SF FILTER AREA
5. 99.9% AT 1.0 MICRON, STANDARD
6. AUTOMATIC PULSE CLEANING "ON DEMAND"
7. 45.5 SF INLINE FILTER, STANDARD
8. 40 CF MATERIAL STORAGE
9. SILO TYPE, ABRASION RESISTANT INLET
10. CUSTOM TUNED SILENCER, UNDER 85 DBA @ 3FT!

FOUR (4) CARTRIDGE FILTERS
244 SQ FT SURFACE AREA

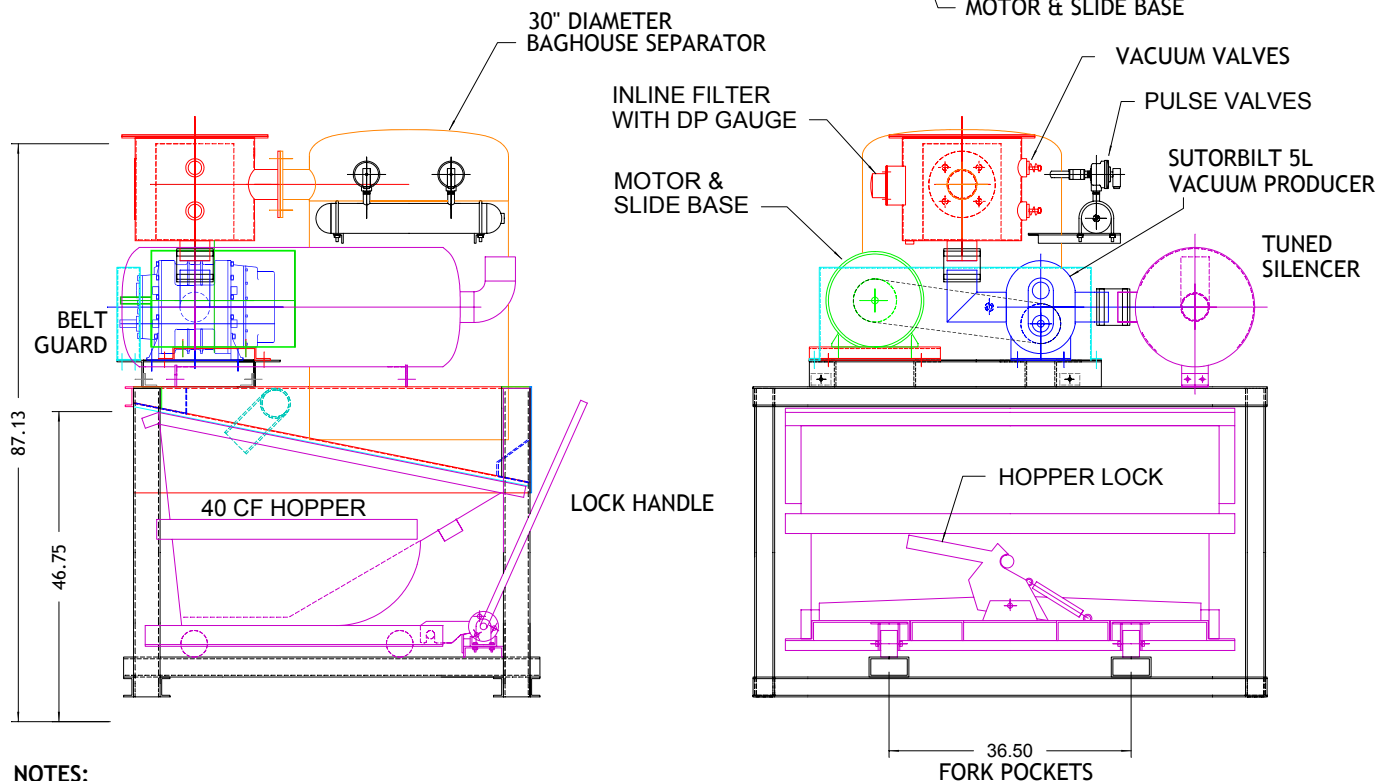
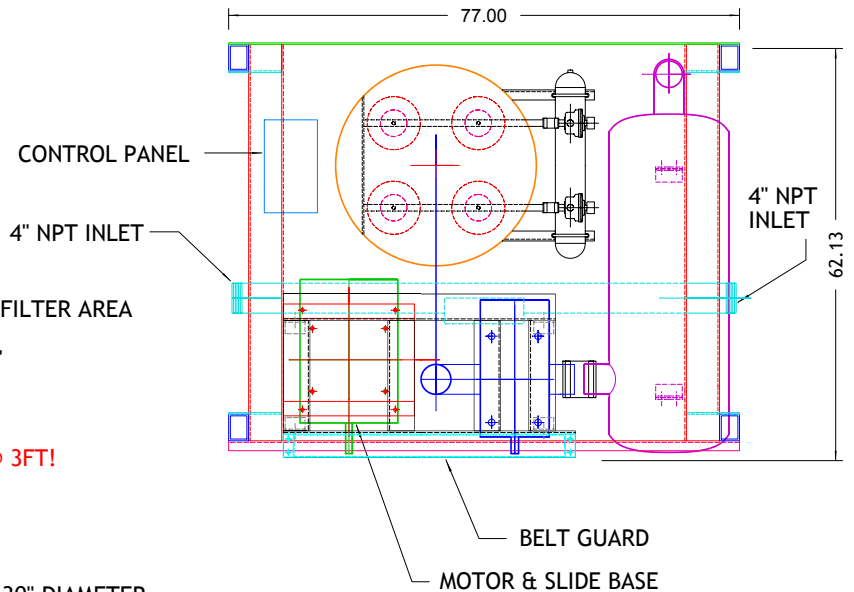

NOTES:

1. SUITABLE FOR WET AND DRY PICKUP
2. EXPECT 130 -160 LBS/MIN PICKUP WITH 3.0" HOSE 25 FT LONG
3. WILL SUPPORT A FIXED PIPE NETWORK UP TO 400 FT LONG WITHOUT MODIFICATION
4. PAINTED PRIME BASE COAT AND TWO TOP COATS OF ENAMEL

**WARNING: VACUUM PRODUCERS THAT CLAIM TO ACHIEVE 18" Hg. CAN *NOT* MAINTAIN VACUUM AT THAT LEVEL WITHOUT OVERHEATING!
ENSURE YOU ASK FOR A WRITTEN PERFORMANCE GUARANTY THAT SPECIFIES 1 HOUR SEALED RUN TIME**

Industrial Air Solutions
Raleigh, NC 877-844-3293

01

10 DEC 02

Rev.

Date

FOR REVIEW

DATE:

DRAWN BY: KRW

SCALE: NTS

DRAWING No.

Rev.

ND2002172 00

PAGE 1 OF 1